

IEEE Guide on Interactions Between Power System Disturbances and Surge-Protective Devices

Sponsor

**Surge-Protective Devices Committee
of the
IEEE Power Engineering Society**

Approved June 14, 1995

IEEE Standards Board

Abstract: Information is provided to users and manufacturers of surge-protective devices (SPDs) about the interactions that may occur between SPDs and power system disturbances. This guide applies to SPDs manufactured to be connected to 50 or 60 Hz ac power circuits rated at 100–1000 V rms. The effects and side effects of the presence and operation of SPDs on the quality of power available to the connected loads are described. The interaction between multiple SPDs on the same circuit is also described.

Keywords: harmonics, noise, power system disturbance, surge-protective device (SPD), swell, voltage sag, voltage surge

The Institute of Electrical and Electronics Engineers, Inc.
345 East 47th Street, New York, NY 10017-2394, USA

Copyright © 1995 by the Institute of Electrical and Electronics Engineers, Inc.
All rights reserved. Published 1995. Printed in the United States of America.

ISBN 1-55937-566-3

No part of this publication may be reproduced in any form, in an electronic retrieval system or otherwise, without the prior written permission of the publisher.

IEEE Standards documents are developed within the Technical Committees of the IEEE Societies and the Standards Coordinating Committees of the IEEE Standards Board. Members of the committees serve voluntarily and without compensation. They are not necessarily members of the Institute. The standards developed within IEEE represent a consensus of the broad expertise on the subject within the Institute as well as those activities outside of IEEE that have expressed an interest in participating in the development of the standard.

Use of an IEEE Standard is wholly voluntary. The existence of an IEEE Standard does not imply that there are no other ways to produce, test, measure, purchase, market, or provide other goods and services related to the scope of the IEEE Standard. Furthermore, the viewpoint expressed at the time a standard is approved and issued is subject to change brought about through developments in the state of the art and comments received from users of the standard. Every IEEE Standard is subjected to review at least every five years for revision or reaffirmation. When a document is more than five years old and has not been reaffirmed, it is reasonable to conclude that its contents, although still of some value, do not wholly reflect the present state of the art. Users are cautioned to check to determine that they have the latest edition of any IEEE Standard.

Comments for revision of IEEE Standards are welcome from any interested party, regardless of membership affiliation with IEEE. Suggestions for changes in documents should be in the form of a proposed change of text, together with appropriate supporting comments.

Interpretations: Occasionally questions may arise regarding the meaning of portions of standards as they relate to specific applications. When the need for interpretations is brought to the attention of IEEE, the Institute will initiate action to prepare appropriate responses. Since IEEE Standards represent a consensus of all concerned interests, it is important to ensure that any interpretation has also received the concurrence of a balance of interests. For this reason IEEE and the members of its technical committees are not able to provide an instant response to interpretation requests except in those cases where the matter has previously received formal consideration.

Comments on standards and requests for interpretations should be addressed to:

Secretary, IEEE Standards Board
445 Hoes Lane
P.O. Box 1331
Piscataway, NJ 08855-1331
USA

IEEE Standards documents may involve the use of patented technology. Their approval by the Institute of Electrical and Electronics Engineers does not mean that using such technology for the purpose of conforming to such standards is authorized by the patent owner. It is the obligation of the user of such technology to obtain all necessary permissions.

Introduction

(This introduction is not a part of IEEE Std C62.48-1995, IEEE Guide on Interactions Between Power System Disturbances and Surge-Protective Devices).

The purpose of this guide is to provide users and manufacturers of surge-protective devices (SPDs) with an understanding of the nature of power system disturbances and SPDs, and of the interactions that may occur between them and between SPDs. Given this understanding, users may be able to take steps to either prevent or mitigate adverse effects of such interactions.

The growth of interest in low-voltage SPDs parallels the increasing number of applications of highly sophisticated electronic equipment that may be exposed and susceptible to surge voltages. Users of SPDs may sometimes be under the impression, or may be led to believe the misconception, that by installing an SPD in their facility or within their equipment, they will provide total immunity to any and all power system disturbances. In reality, SPDs will respond to and affect some power system disturbances but not others. The effects that SPDs will have on power system disturbances are often less than desired. SPDs installed at various locations in the wiring systems as well as in equipment may interact with those wiring systems and with each other. In this scenario, the effect of any given SPD is imprecise and predictable only within wide limits.

The SPDs discussed herein are intended to limit transient overvoltages that can appear in low-voltage ac power systems having service voltages of 1000 V or less.

The present document is one member of the IEEE C62 family that deals with power system surges and surge protection. IEEE Std C62.41-1991 characterizes and provides information on surge voltages in low-voltage ac power circuits. Other C62 documents describe performance characteristics of SPDs, recommend standard test protocols for verifying SPD performance, and provide SPD applications guidance.

Suggestions for improvements to this guide will be welcomed. They should be sent to the Secretary, IEEE Standards Board, Institute of Electrical and Electronic Engineers, 445 Hoes Lane, P.O. Box 1331, Piscataway, NJ 08855-1331.

At the time this standard was completed, the Working Group on Surge Characterization in Low-Voltage Circuits had the following membership:

Hans J. Steinhoff, *Chair*

George J. Bagnall
Francis P. Drake
Barry Epstein
Frank Fiederlein

H. Ed Foelker
Ernie Gallo
François D. Martzloff
Kurt A. Meindorfer

Richard Odenberg
Alan W. Rebeck
Dennis P. Symanski
Donald M. Worden

Other individuals who have contributed review and comments are as follows:

Chrysanthos Chrysanthou
Robert J. Davidson
Michael Fluegeman
James Forte

Gary L. Goedde
Pete A. Goodwin
Joseph L. Koepfinger
Michael Parente
Pete Richman

Louis Schulman
Ronald B. Standler
Matt Wakeham
Bernie I. Wolff

The following persons were on the balloting committee:

George J. Bagnall	Bengt Johnnerfelt	William T. Rhodes
Charles L. Ballentine	Stanley S. Kershaw	Ronald B. Standler
James J. Burke	Joseph L. Koepfinger	Hans J. Steinhoff
Michel De Nigris	Gerald E. Lee	Keith B. Stump
Cliff C. Erven	Jeff Mackevich	Dennis P. Symanski
H. E. Foelker	François D. Martzloff	E. R. Taylor
Gilbert L. Gaibrois	R. D. Melchior	Arnold Vitols
George S. Haralampu	E. H. Morrow, Jr.	Steven G. Whisenant
John A. Hetrick	Richard Odenberg	Jonathan J. Woodworth
David W. Hutchins	Joseph C. Osterhout	Donald M. Worden
	Michael Parente	

At the time this standard was published, it was under consideration for approval as an American National Standard. The Accredited Standards Committee on Surge Arresters, C62, had the following members at the time this document was sent to letter ballot:

Joseph L. Koepfinger, Chair

John A. Gauthier, Secretary

<i>Organization Represented</i>	<i>Name of Representative</i>
Alliance for Telecommunications Industry Solutions.....	C. Chrysanthou
Association of American Railroads	Wayne Etter
Bonneville Power Administration	G. E. Lee
Canadian Standards Association (Liaison)	D. M. Smith
Electric Light and Power.....	R. A. Jones H. E. Foelker W. A. Maguire J. W. Wilson M. C. Mingoia (<i>Alt.</i>) F. Martinez
Institute of Electrical and Electronics Engineers	J. L. Koepfinger J. J. Burke G. L. Gaibrois W. H. Kapp S. S. Kershaw, Jr. C. Hansell (<i>Alt.</i>) Edgar Taylor (<i>Alt.</i>)
National Electrical Manufacturers Association	Dennis W. Lenk Bernhard Wolff D. Worden Larry Bock J. Woodworth
National Institute of Standards and Technology	F. D. Martzloff
Rural Electrification Administration	George J. Bagnall
Underwriters Laboratories	P. Notarian Larry Williams (<i>Alt.</i>)
Members-at-Large.....	J. Osterhout B. Panesar R. B. Standler

When the IEEE Standards Board approved this standard on June 14, 1995, it had the following membership:

E. G. “Al” Kiener, *Chair*

Donald C. Loughry, *Vice Chair*

Andrew G. Salem, *Secretary*

Gilles A. Baril
Clyde R. Camp
Joseph A. Cannatelli
Stephen L. Diamond
Harold E. Epstein
Donald C. Fleckenstein
Jay Forster*
Donald N. Heirman

Richard J. Holleman
Jim Isaak
Ben C. Johnson
Sonny Kasturi
Lorraine C. Kevra
Ivor N. Knight
Joseph L. Koepfinger*
D. N. “Jim” Logothetis
L. Bruce McClung

Marco W. Migliaro
Mary Lou Padgett
John W. Pope
Arthur K. Reilly
Gary S. Robinson
Ingo Rusch
Chee Kiow Tan
Leonard L. Tripp

*Member Emeritus

Also included are the following nonvoting IEEE Standards Board liaisons:

Satish K. Aggarwal
Richard B. Engelman
Robert E. Hebner
Chester C. Taylor

Paula M. Kelty
IEEE Standards Project Editor

Contents

CLAUSE	PAGE
1. Overview.....	1
1.1 Scope.....	1
1.2 Purpose.....	1
2. References.....	2
3. Definitions.....	2
4. Power system disturbances	3
4.1 Surges.....	4
4.2 Swells.....	5
4.3 Temporary overvoltages (TOVs).....	5
4.4 Notches	5
4.5 Sags	6
4.6 Temporary undervoltages	6
4.7 Harmonics	6
4.8 Noise	7
5. Interactions of power system disturbances and SPDs.....	8
5.1 Response to voltage surges	8
5.2 Response to swells	10
5.3 Response to TOVs	10
5.4 Response to notches.....	10
5.5 Response to sags	10
5.6 Response to temporary undervoltages	10
5.7 Response to harmonics	10
5.8 Response to noise.....	11
6. Side effects.....	11
6.1 Benefits for downstream and upstream loads	11
6.2 Partial loss of power with voltage-switching devices.....	11
6.3 Surge current introduction into a facility	12
6.4 Voltage oscillations caused by SPDs.....	12
6.5 Effects of inductance between SPDs	12
6.6 SPD failure-mode effects on power systems	12
6.7 Effects of SPD peripheral components on power systems	13
ANNEXES	
Annex A Description of environment	14
Annex B Bibliography.....	17

IEEE Guide on Interactions Between Power System Disturbances and Surge-Protective Devices

1. Overview

1.1 Scope

This guide applies to surge-protective devices (SPDs) manufactured to be connected to 50 or 60 Hz ac power circuits rated at 100–1000 V rms.

This guide describes the effects on SPDs of power system disturbances occurring in these low-voltage ac power circuits. The disturbances are not limited to surges. The effects and side effects of the presence and operation of SPDs on the quality of power available to the connected loads are described. The interaction between multiple SPDs on the same circuit is also described.

This guide will discuss both voltage and current surges. The current surges discussed in this guide are the result of voltage surges. Current surges that are solely the result of load changes and do not result in voltage increases, such as a short circuit, are not discussed in this guide.

An SPD is a device whose primary purpose is to provide surge protection. Devices discussed in this guide contain at least one nonlinear component for diverting surge current and/or dissipating surge energy, such as a metal oxide varistor (MOV), silicon avalanche diode (SAD), thyristor, or spark gap. Uninterruptible power supplies, ferroresonators, motor-generators, and filters containing only inductive and/or capacitive components are not considered SPDs in this guide.

1.2 Purpose

The purpose of this document is to provide information on the interactions between power system disturbances and SPDs that is not readily available in other standards. This document provides summary information on power system disturbances that affect or may affect SPDs. The description of the interactions is intended to educate the potential user of such SPDs as to what he or she can expect from such devices.

2. References

References contain information that is implicitly adopted in the present document; complete comprehension of the interactions described in this guide shall require the reader to consult those sources for the details of a particular subject. They are cited in the text by their standards organization designation.

ANSI C84.1-1989, American National Standard Voltage Ratings for Electric Power Systems and Equipment (60 Hz).¹

ANSI/NFPA 70-1993, National Electrical Code.²

IEEE Std C62.41-1991, IEEE Recommended Practice on Surge Voltages in Low-Voltage AC Power Circuits (ANSI).³

3. Definitions

The purpose of this clause is to define those terms that will aid in the understanding of the concepts in this guide. Where possible, definitions were obtained from IEEE Std 100-1992 [B3];⁴ these are identified by an asterisk (*). The second choice was to obtain them from other appropriate sources. The final choice was to create a new definition that conveys a common understanding for the word as used in the context of this guide.

3.1 combination-type SPD: An SPD that incorporates both voltage-switching-type components and voltage-limiting-type components that may exhibit voltage switching, voltage limiting, or both voltage-switching and voltage-limiting behavior, depending upon the characteristics of the applied voltage.

3.2 commercial power: Electrical power furnished by the electric power utility company.*

3.3 harmonic: A sinusoidal component of a periodic wave having a frequency that is an integral multiple of the fundamental frequency.*

3.4 harmonic distortion: The mathematical representation of the distortion of the pure sine waveform.

3.5 mains: The ac power source available at the point of use in a facility. It consists of the set of electrical conductors (referred to by terms including *service entrance*, *feeder*, or *branch circuit*) for delivering power to connected loads at the utilization voltage level.*

3.6 noise: Unwanted electrical signals that produce undesirable effects in the circuits of the control systems in which they occur. (For this guide, *control system* is intended to include sensitive electronic equipment in total or in part.)*

3.7 nominal voltage: A nominal value assigned to a circuit or system for the purpose of conveniently designating its voltage class (as 120/240, 480Y/277, 600, etc.).*

¹ANSI publications are available from the Sales Department, American National Standards Institute, 11 West 42nd Street, 13th Floor, New York, NY 10036, USA.

²NFPA publications are available from Publication Sales, National Fire Protection Association, 1 Batterymarch Park, P.O. Box 9101, Quincy, MA 02269-9101, USA.

³IEEE publications are available from the Institute of Electrical and Electronics Engineers, 445 Hoes Lane, P.O. Box 1331, Piscataway, NJ 08855-1331, USA.

⁴The numbers in brackets preceded by the letter B correspond to those of the bibliography in annex B.

3.8 nonlinear load: Electrical load that draws current discontinuously or whose impedance varies during the cycle of the input ac voltage waveform.

3.9 nonlinear load current: Load current that is discontinuous or is not proportional to the ac voltage.

3.10 notch: A switching (or other) disturbance of the normal power voltage waveform, lasting less than a half-cycle, which is initially of opposite polarity than the waveform, and is thus subtractive from the normal waveform in terms of the peak value of the disturbance voltage. This includes complete loss of voltage for up to a half-cycle.

3.11 overvoltage: A rms increase in the ac voltage, at the power frequency, for durations greater than a few seconds.

3.12 power disturbance: Any deviation from the nominal value (or from some selected thresholds based on load tolerance) of the input ac power characteristics.

3.13 sag: A rms reduction in the ac voltage, at the power frequency, for durations from a half-cycle to a few seconds.

3.14 surge: A transient wave of voltage or current. The duration of the surge is not tightly specified but is usually less than a few milliseconds.

3.15 surge-protective device (SPD): An assembly of one or more components intended to limit or divert surges. The device contains at least one nonlinear component.

3.16 surge-response voltage: The voltage profile appearing at the output terminals of a surge-protective device and applied to downstream loads, during and after a specified impinging surge, until normal, stable conditions are reached.

3.17 swell: A momentary increase in the power frequency voltage delivered by the mains, outside of the normal tolerance, with a duration of more than one cycle and less than a few seconds.*

3.18 voltage-limiting-type SPD: An SPD that has a high impedance when no surge is present but reduces it continuously with increased surge current and voltage. Common examples of components used as nonlinear devices are varistors and suppressor diodes. These SPDs are sometimes called “clamping-type” SPDs.

3.19 voltage-switching-type SPD: An SPD that has a high impedance when no surge is present, but can have a sudden change in impedance to a low value in response to a voltage surge. Common examples of components used as nonlinear devices are spark gaps, gas tubes, and silicon-controlled rectifiers. These SPDs are sometimes called “crowbar-type” SPDs.

4. Power system disturbances

Power system disturbances are increases or decreases in the system voltage or the power frequency beyond what is considered the normal tolerance (as described by ANSI C84.1-1989,⁵ for instance). The changes in voltage on the ac mains can range from complete loss (no voltage) for various durations lasting up to seconds, minutes, or even hours, to very high-magnitude, short-duration impulses of 50 or more times the normal system voltage lasting for no more than a few millionths of a second. Some of these disturbances can have an undesirable effect on the connected equipment, including SPDs. The equipment and SPDs discussed in this guide are connected to the low-voltage mains (100–1000 Vac), though some of the disturbances orig-

⁵Information on references can be found in clause 2.

inate on the high-voltage distribution system. SPDs are intended to reduce the severity of some power system disturbances but may be unable to do anything about others.

Before discussing the interactions between power system disturbances and SPDs in detail, the power system disturbances will be described along with a brief summary of the interactions. Table 1 presents a summary of the interactions.

Table 1—Power system disturbance and SPD interaction

Power system disturbances	Surges	Swells	Temporary overvoltages (TOVs)	Notches	Sags	Temporary undervoltages	Harmonics	Noise
SPD effect on disturbances	Possible reduce	Possible reduce	Reduce	None	None	None	None	Possible
Effect on SPD	Some	Possibly adverse	Possibly adverse	None	None	None	Possible	None

4.1 Surges

Surges are described in IEEE Std C62.41-1991. They include short-duration, high-energy surges; bursts of high-frequency transients; and high-energy, lower-voltage, and lower-frequency disturbances due to power-system operations.

Surges can be subdivided into externally generated and internally generated surges. External surges are those surges generated outside a facility and brought into the facility by the utility wires. Internal surges are generated within a facility by the user's own equipment. External surges are typically more severe but less frequent than internal surges.

Externally generated surges result from lightning, fuse operation, and power system switching. Lightning surges may result from a direct strike to the power service or from voltages induced by strikes to nearby lines or to earth. Buried power cables are not immune to lightning surges. Lightning currents can flow along the sheath of a buried cable and induce voltages on the conductors within the cable. Wires inside a plastic conduit are also subject to induced voltages that might be capable of damaging vulnerable equipment. Capacitor switching by the utility can also generate surges.

Internally generated surges typically result from switching inductive or capacitive loads. They may also result from a fuse or breaker opening in an inductive circuit. The operation of an SPD can also contribute internal surges.

SPDs are intended to reduce surge voltages by conducting the surge currents to neutral, ground, or to another phase. In the process, there is voltage division with the impedance of the rest of the current path; hence, there is less surge voltage at the point of connection of the SPD than there would be without the SPD. SPDs absorb some surge energy and dissipate it in the form of heat (a gas tube or an air gap would absorb very little energy). They are typically intended to do this for surges ranging in duration from less than 1 μ s to up to 10 ms. Surges outside the specified capability of the SPD might damage or destroy the SPD.

4.2 Swells

Swells might result from switching operations in the utility distribution system, power switching from one source to another, intermittent loss of a neutral connection, a phase-to-ground fault, such as a flashover of an insulator on one phase of a multiphase system, or possibly a high-voltage conductor contacting a low-voltage conductor. A phase-to-ground fault on a multiphase supply system can result in the voltage of the unfaulted phases increasing to as much as 1.91 times the normal amplitude (1.732 plus nominal system voltage tolerance which can be as much as 10%), in extreme cases, for up to several seconds.

A swell can result from switching a heavy load quickly from one power source to another. An example of this is a load with motors switched from a standby generator to commercial power. The running motor, disconnected from its power source, will generate a back emf. If this motor, at the peak of its back emf, is connected to another power source at the peak of the line voltage, the resulting voltage might be doubled momentarily [B1]). A swell might also result from the loss or disconnection of a high-current load.

If the voltage is high enough, a swell is likely to damage or destroy the SPD. There are indications, although not documented in published papers, that (because of their larger energy content) swells may damage heavy-duty SPDs more often than do surges.

4.3 Temporary overvoltages (TOVs)

TOVs are power system disturbances with a duration typically longer than that of swells. A TOV might be caused by a fault on one phase of a three-phase system, a short in the primary winding of a transformer, a power cross from a higher-voltage line. Overvoltages may occur when cogeneration units are present on distribution systems. Overvoltages can be caused when a distribution system generator and part of the distribution network are separated from the utility. This is called the islanding condition and could be caused by an opening of the substation breaker or a feeder recloser. The overvoltages can be caused by ungrounded transformer connections, self-excitation, or ferroresonance. When a single line-to-ground fault occurs and the substation breaker opens, the system becomes a three-wire, ungrounded system driven by the delta-connected distribution system generator. The line-to-neutral voltage will attempt to rise to the line-to-line voltage (1.732 times the line-to-neutral voltage). The 10% tolerance on the nominal voltage can increase this to 1.91 times the nominal line-to-neutral voltage. Fault-protection schemes used at the cogeneration site would be expected to sense the islanding condition and disconnect from the system in a matter of a few seconds [B6].

An intermittent or loose neutral connection on a 120/240 V three-wire single-phase system on the line side of an SPD can put as much as 240 V across the line and neutral connections of the SPD if the SPD has no load connected to it and the other line has a load on it downstream from the loss of neutral. (See figure 1.)

TOVs beyond the rating of the SPD might damage or destroy the SPD.

4.4 Notches

Notches in the ac voltage wave are frequently caused by the action of electronic switches, such as semiconductor controlled rectifiers (SCRs) or switchmode power supplies (nonlinear power supplies) that draw a heavy load current during a small portion of the sine wave. Notches might be noted in a heavy industrial environment that has loads controlled by SCRs. Notches might also be seen on the line side of some uninterruptible power supplies.

Notches have no effect on most SPDs, and SPDs have no significant effect on notches. Capacitors added to some SPDs might have a minor effect on some small notches.

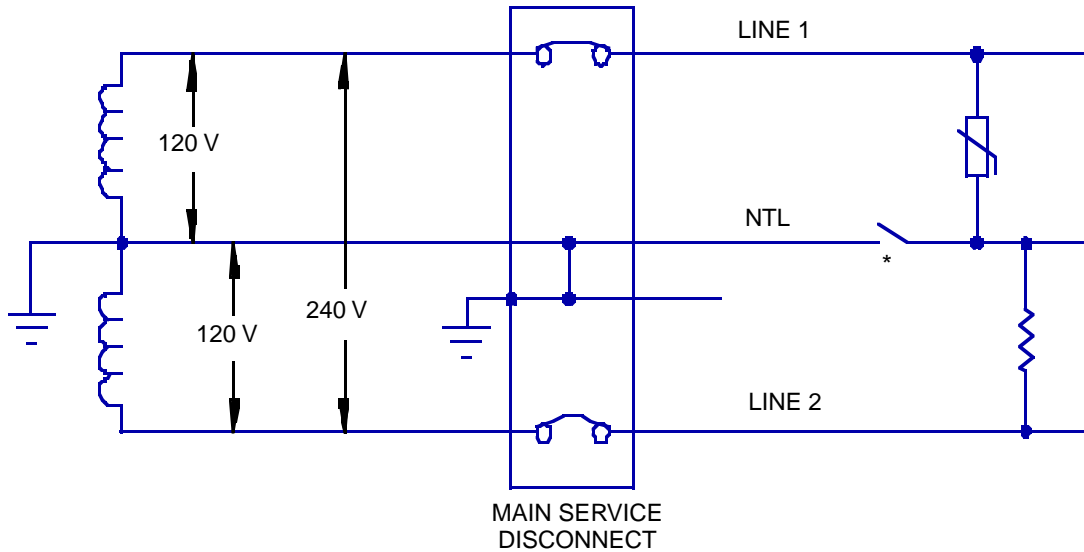

*Loose or intermittent connection

Figure 1—Example of loose connection causing overvoltage

4.5 Sags

Sags (also called “dips” in the IEC Vocabulary) result from various types of power system disturbances. The most frequent cause of a severe sag is a fault on an adjacent feeder. For this type of sag, the duration is equal to the clearing time of the fuse, breaker, or recloser involved in the faulted feeder—typically, a few cycles. Mild sags can be caused by a fault on distant feeders or by inrush current into a nearby load. Their duration is determined by the clearing time of the distant fault (a few cycles), or by the inrush characteristics of the nearby load (from a few to tens of cycles).

For most SPDs, sags will not involve a significant interaction, neither sags on SPDs nor SPDs on sags. See 5.5 for examples of rare cases where some interactions might be involved. The operation of a voltage-switching SPD might act as a virtual short circuit and thus cause a sag in a connected or adjacent circuit; see 6.2.

4.6 Temporary undervoltages

Temporary undervoltages may be the result of power system faults that are of longer duration than those causing sags. These power system faults might include the case of a fault on one phase of a three-phase system in an area of high ground resistance, resulting in a relative long delay before a breaker clears the fault. Temporary undervoltages might also result from a temporary load on the power system that exceeds its capacity.

For most SPDs, temporary undervoltages will have no effect on the SPD, and the SPD will have no effect on the temporary undervoltage.

4.7 Harmonics

Harmonic distortion is the misshaping of the sinusoidal waveform resulting from the algebraic addition to the fundamental waveshape of higher frequency sine waves that are integer multiples of the fundamental frequency and known as harmonics. Typically, the slope of the resulting waveshape is steeper and the peak is

flatter than the fundamental waveshape. In an ac distribution system, even harmonics are not present when the positive and negative half-cycles are symmetrical about the x axis (i.e., they have the same shape and amplitude). Odd triplen harmonic currents (odd multiples of three, namely the 3rd, 9th, 15th, 21st, etc., harmonic) of a three-phase, four-wire power system, being zero sequence components, are additive in the neutral conductor. Abnormal levels of the odd triplen harmonic currents can cause overheating of the neutral conductor and other neutral components. Abnormal levels of harmonic currents, in general, can cause overheating of power sources (transformers, generators, etc.) nuisance tripping of circuit breakers, and failure of power factor correction capacitors. Abnormal levels of harmonic voltage can cause overheating of magnetic devices (motors, transformers, coils, etc.) and misoperation of sensitive electronic equipment, including those that rely on zero crossings for timing.

SPDs containing large capacitors might contribute to any or all of the above cited problems. The allowable voltage *total harmonic distortion* (THD) typically cited by electronic and computer manufacturers is 5% or less. Voltage THD inherent in a utility feed to a facility normally ranges from <1–3%. THD in excess of 5% is not uncommon. Switch-mode power supplies utilized in many computers are nonlinear loads (the current waveform does not conform to the waveform of the impressed voltage). Since current is drawn in short bursts of high amplitude, a high impedance in the power delivery system or series-connected SPD can result in current starvation and flattening of the top of the voltage sine wave. Harmonic current distortion up to 20% is not uncommon.

Most SPDs will have no effect on harmonics. SPDs with inductive and capacitive components might be prone to failure caused by harmonics prevalent on the distribution system.

4.8 Noise

A variety of asynchronous interference in addition to the surges and other transients covered under 4.1 may appear on the ac mains. The most prevalent of these is random bursts of noise, with dominant frequency spectra ranging from 100 kHz to 10 MHz, caused by corona or partial discharge. The source is usually inside of equipment operating within a facility, but it may also lie outside the facility, in which case spectra will usually be limited to some hundreds of kilohertz.

Conducted *electromagnetic interference* (EMI) (or noise) is a high-frequency, low-current, low-energy waveform superimposed on the sine wave of the ac mains. The frequency of the conducted EMI can range from the low kilohertz into the megahertz region. This low-level interference is typically characterized by a voltage of less than 50 V and an associated current of less than 1 A. Noise is not a component-damaging anomaly, but can be very costly in the form of data errors, lost data, or down time.

Potential noise sources in electrical distribution systems include motors, transformers, capacitors, generators, lighting systems, power conditioning equipment, and SPDs. Harmonics produced from nonlinear loads on the distribution system (switch mode power supplies, SCRs in lighting systems, ac line regulators, voltage-switching surge protectors) can produce noise frequencies from the audio into the radio frequency range. *Electrostatic discharge* (ESD) induced onto the electrical distribution contains a great deal of high-frequency noise. Resonance to *radio frequency interference* (RFI) occurs when wire lengths match interfering signal wavelengths and are the strongest at multiples of one quarter wavelength.

Interaction between voltage-switching surge protectors, employing a gas tube or SCR, and capacitors can result in high-frequency voltage oscillations on a distribution system. The voltage oscillation occurs when the notch created by the firing of the gas tube, or switching of the SCR, appears on the system as a high-amplitude square wave pulse. This pulse causes the distribution system to ring at its natural frequency. The inverters in some uninterruptible and standby power supplies operate at frequencies of 20 kHz and above and can result in noise frequencies being reflected back onto the input distribution system from the UPS or standby power supply.

Properly applied shunt-connected SPDs will have negligible effects on noise. Series-connected SPDs are often designed to include series-connected inductors together with shunt-connected capacitors that are capable of reducing some noise.

5. Interactions of power system disturbances and SPDs

5.1 Response to voltage surges

The response of SPDs to voltage surges depends, first of all, on their design, or more specifically, on the SPD components used. SPD components typically respond to overvoltages by changing from a high-impedance state to a lower-impedance state. Voltage-switching (crowbar) devices change from a high impedance to a low impedance when the turn-on or breakdown voltage is exceeded. The voltage across the voltage-switching SPD typically drops to a few tens of volts. Voltage-limiting (clamping) devices attempt to maintain the voltage at a relatively low level above the turn-on or conduction voltage. As the voltage across the voltage-limiting device increases, the impedance continues to decrease, permitting more current flow. In the process of responding to the surge voltage, the SPD diverts the surge currents to the grounded power conductor, or to a grounding conductor or another power conductor. The current conducted by the nonlinear SPD components increases very rapidly when a specified voltage is exceeded. Hence, the response of SPDs to surges consists of three key features. One, SPDs divert the surge current. Two, SPDs limit the peak voltage passed to downstream equipment by dropping some of the incident overvoltage across the impedance of the power-frequency mains. Three, part of the energy of the surge is converted into heat in the nonlinear element.

Some SPDs contain components connected in series with the input and output terminals of the SPD (see figure 2), as well as the shunt-connected SPD components. (See figure 3 for an example of the typical shunt-connected design.) Internal linear elements—typically, inductances—impede the flow of surge current while nonlinear elements divert it. Hence, series-connected SPDs limit the peak voltage passed to downstream equipment by dropping some of the incident overvoltage inside the SPD and dropping some of it outside of the SPD across the impedance of the ac mains.

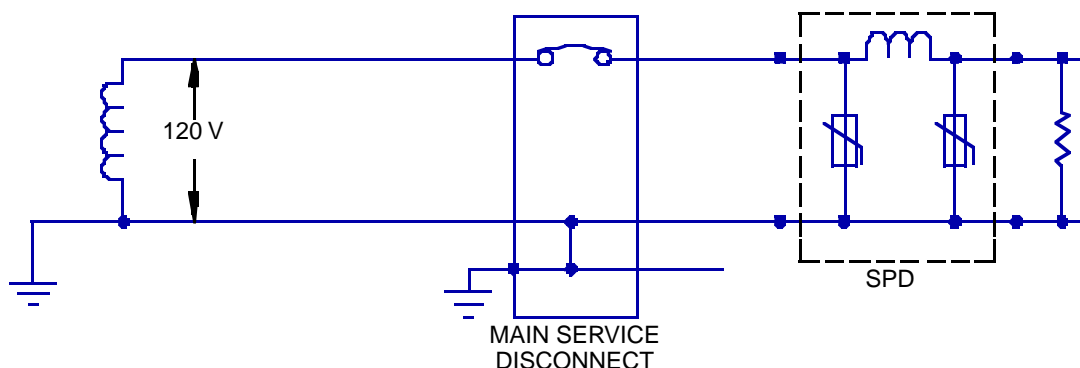

Figure 2—Example of series-connected SPD

The basic surge response voltage characteristics of SPDs depend on the type of nonlinear component used, which can be of a voltage-limiting or voltage-switching type, or a combination of the two types. For voltage-limiting devices, the surge response voltage tends to be lowest at low current and to increase somewhat at higher currents. For voltage-switching devices, the current conducted tends to switch abruptly from very low to very high values when a device turns on, and the voltage across the SPD may drop when current flows.

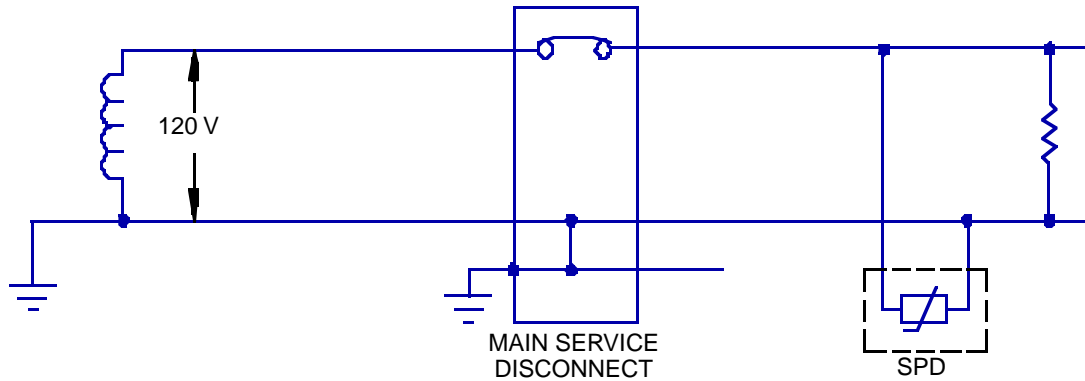

Figure 3—Example of shunt-connected SPD

Voltage-switching components are sometimes used in series with voltage-limiting components. Voltage-switching components are also used in parallel with voltage-limiting components. SPDs using voltage-switching and voltage-limiting components in series or in parallel are called combination type SPDs. For combination type SPDs the surge response can be a combination of the voltage-switching and voltage-limiting action.

The response of SPDs to surges, including the surge-response voltage, can also depend on the characteristics of the surge itself. The surge response voltage can be a function of the peak amplitude, the rate-of-rise of current, and the rate-of-rise of voltage. Additionally, the installed characteristics of SPDs can be affected by parasitic inductance in the leads connecting the SPD to the ac mains. Response time is sometimes thought to be an important consideration in the performance of an SPD. In actuality, the response time of the majority of the surge protective components used today, such as MOVs, SADs, thyristors, and other solid-state components, is similar and in the nanosecond range. In this time frame, lead-length has a greater effect on the response of the device than does any sub-nanosecond component response time.

When SPDs divert surge current, some of the energy of the surge is dissipated not only in the SPD, which may include its linear and nonlinear components, but also in the impedance of the ac mains and its loads [B7].

SPDs may reflect surge energy back toward the source. Voltage-switching devices, which breakover to a low voltage, reflect more surge energy than voltage-limiting devices. On the other hand, when voltage-switching and combination-type SPDs divert surge current, they also may continue to conduct follow current from the ac mains for up to one power-frequency cycle. This can affect the mains voltage and the connected equipment.

Voltage side effects can be created as SPDs divert surge currents. See clause 6 for a discussion of these effects.

The effects of surges on SPDs partially depend on the type of components used in the SPD. Components might have limits to the number of surges of a certain amplitude and waveform that they can survive. On some SPDs the voltage at a particular current increases with repetitive surges, on some it decreases, and some show very little change. Some SPD components might exhibit a trend towards failure while others remain well within specification until they fail.

5.2 Response to swells

The response of a SPD to a swell depends on the amplitude and duration of the swell and on the protective characteristics of the device. If the peak of the voltage during the swell does not exceed the turn-on voltage of the SPD, the SPD will have no effect on the swell. If the voltage of the swell exceeds the turn-on voltage, the SPD will try to suppress the swell. In the case of a voltage-limiting type SPD, the effect on the SPD may be minimal because the SPD may still be operating in the high-resistance region. In the case of a voltage-switching type SPD, the swell may be reduced significantly during each half cycle, if the sparkover voltage or turn-on voltage of the SPD is exceeded.

If the amplitude and duration of the swell is such that the energy-handling capability of the SPD components is exceeded, the SPD will be damaged or destroyed. Swells probably cause more SPD failures than lightning or other surges [B5].

5.3 Response to TOVs

The response of SPDs to TOVs is the same as it is for voltage surges and swells. If the voltage exceeds the turn-on voltage of the SPD, the SPD will try to suppress the overvoltage to the best of its ability. The TOV, being of a longer duration than voltage surges and swells, has the capability to deliver more energy, possibly destructive energy, to the SPD than most surges or swells.

5.4 Response to notches

SPDs employing only nonlinear elements will be unresponsive to notches in the ac voltage waveshape. SPDs employing capacitors might have some effect on the notches, depending on the size of the capacitor, the kVA rating of the power system, and the degree of notching. In general, an SPD cannot be relied on to fill notches in a power system.

5.5 Response to sags

Shunt-connected SPDs will be unresponsive to undervoltage conditions if they contain only nonlinear components. More complex series-connected SPDs may employ both shunt and series linear components. An example in which the SPD may be affected could occur when a series-connected SPD is used to protect a constant power load. In this case, when the voltage is reduced, the current will be increased. This could result in a load current through the SPD that could exceed its through-current rating.

5.6 Response to temporary undervoltages

The response of SPDs to temporary undervoltages is the same as their response to sags, discussed in 5.5. In most cases, the SPD will do nothing, and in a special situation, a series-connected SPD could be damaged.

5.7 Response to harmonics

The harmonic component that is typically thought of as causing problems on the mains is harmonic current. Shunt-connected SPDs not containing capacitors do not react to harmonic currents. These devices will react to harmonic voltages in the same manner that they react to any voltage. If the amplitude of the harmonic voltage exceeds the threshold or turn-on voltage of the device, the device will go into conduction and try to reduce the voltage level. Currents in some SPDs can increase with the presence of harmonic voltages. The increased current might shorten the life of the SPD. SPDs with capacitors, under some conditions, might react to the harmonics in a manner that could damage the capacitors. The flattening of the ac sine wave might reduce possible stress on some SPDs.

Capacitor failure can result from high harmonic content in the electrical distribution system. The impedance [$X_c = 1/(2\pi fC)$] of a capacitor decreases as the frequency of the applied voltage increases. At high frequencies, the impedance of capacitors added in an SPD for filtering can be so low as to constitute a virtual short circuit. If the current available at these frequencies is high enough, capacitor failure will occur. Unusually high currents can develop if harmonics establish a parallel-resonant condition in the capacitor circuit. The resonant circuit amplifies the harmonic current resulting in blown fuses or nonlinear load failure.

5.8 Response to noise

The response of an SPD to noise will depend on the design of the SPD and the amplitude and frequency of the noise pulses. An SPD employing only nonlinear elements will show little response to noise whose amplitude does not exceed the switching or limiting voltage of the device. SPDs employing MOVs and/or SADs might demonstrate some attenuation of the noise pulses because of their capacitance. This incidental noise attenuation might be less effective on shunt-connected SPDs because of the inductance of the connecting leads.

6. Side effects

6.1 Benefits for downstream and upstream loads

The purpose of SPDs is to limit surge voltages by diverting surge currents and converting surge energy into heat. The greatest benefits will be for loads downstream of the SPD if the surge entered the systems upstream of the SPD. There may be some benefit to upstream loads, depending on the proximity of the load to the SPD and the impedance presented to the surge by the wiring between the load and the SPD.

An SPD at the service entrance can reduce the incoming lightning and switching surges to tolerable voltages and energies if an adequate device is selected and is properly installed. (Proper installation includes a low-impedance connection of the SPD to ground.) These voltages may again increase in amplitude as the surge remnant travels through the wiring system, if there is no additional SPD close to the load. For this reason, additional SPDs are recommended to be installed downstream from the main SPD at the service entrance. These devices should be placed as close as possible to the sensitive loads.

The interaction between two or more SPDs on the same power system is an important consideration. The planned interaction between SPDs is sometimes termed *cascade coordination*. Two or more SPDs may be required to protect some equipment because the equipment might be installed too far from the service entrance for the service entrance SPD to protect it against internally generated surges. The length of the leads required to connect an SPD to a large service cabinet might result in the surge response voltage being greater than can be tolerated by the equipment to be protected, thus requiring another SPD at the equipment. The SPD at the service entrance should be capable of handling lightning surges, but the second SPD at the equipment needs to handle only the surge response voltage of the first SPD and part of any surges introduced into the system between the two SPDs.

Cascaded SPDs are capable of having undesirable interactions if they are not properly coordinated. The downstream SPD might be subjected to more energy than it was designed for if its operating voltage is not coordinated with the surge-response voltage of the upstream SPD. This applies also to the coordination between the SPD at the service entrance and at the utility transformer [B4], [B8].

6.2 Partial loss of power with voltage-switching devices

Side effects of the use of SPDs can result both from the type of devices used and from the method of installation of such devices. A voltage-switching device, such as an air gap or a gas tube, can reflect surges back

towards the source because of the rapid change in voltage from the firing voltage of the device to the arc voltage which is typically 20–30 V. The voltage across the voltage-switching device will remain at the low arc voltage until the device clears, which is typically near the next zero crossing of the ac line voltage or current. This low voltage across the voltage-switching component can produce a reduction of the mains voltage for a significant portion of the half cycle, to a level where relays can drop out and some loads can suffer from a power interruption.

6.3 Surge current introduction into a facility

Side effects from the installation of SPDs include high surge currents introduced into facility wiring if SPDs are installed at or within loads but not at the service entrance. This situation is a common occurrence because many types of electronic devices are equipped with MOVs by their manufacturers. These devices include TVs, VCRs, microwave ovens, washers, dryers, etc. Many users of personal computers also purchase plug-in or cord-connected SPDs.

In the case where an SPD is installed at the service entrance and also at (or within) the load equipment, undesirable side effects can still occur. The SPD at the load can have a lower surge response voltage than the SPD at the service entrance. This situation can occur because many MOVs used in equipment or plug-in protectors are selected on the basis of their low clamping voltage (such as 130 Vac rated MOVs for 120 V mains). The SPD at the service entrance might use MOVs rated for 175 Vac (secondary arrester rating) or even higher for 120 V mains. Many other SPDs installed at the service entrance use 150 Vac rated MOVs. This combination of a higher-voltage SPD followed by a lower-voltage SPD can result in a significant amount of surge current flowing towards the lower-voltage SPD at the equipment. This surge current in the building wiring can induce undesirable or harmful voltages in nearby communications or signal wiring. On the other hand, this scenario depends upon the impedance of both devices and the interconnecting wiring at the current in question. For example, a device with more or larger suppression components at the service entrance (even with a higher turn-on voltage) can actually present a lower impedance at significant currents than a smaller downstream device with a lower turn-on voltage.

6.4 Voltage oscillations caused by SPDs

Studies have shown that voltage oscillation occurs downstream from an operating SPD. The amplitude of this oscillation depends on the circuit parameters as well as on the incoming surge voltage and waveshape. In special cases, the maximum voltage may be more than twice the surge-response voltage [B2].

6.5 Effects of inductance between SPDs

The inductance between cascaded SPDs might have different effects on the surge-response voltage at the location where the SPDs are connected to the mains. For example during the front of the surge, while the current is rising, the first SPD will see the voltage of the second SPD plus the voltage across the inductance. During the tail of the surge, the first SPD will also see the voltage across the second SPD and across the inductance, but since the voltage across the inductance is now negative, the voltage across the first SPD will now be less than the voltage across the second SPD. Thus, the second SPD is influencing the voltage across the first SPD. The second SPD may therefore be subjected to much more energy than was intended [B2].

6.6 SPD failure-mode effects on power systems

A parallel-connected SPD can fail as an open circuit, a high-impedance fault condition, or a low-impedance short-circuit condition. These failures can result from excessive or repetitive surge voltages or currents, from prolonged TOVs, or from random component failures. These failures can cause both surge voltages and under-

voltages on power systems as well as short-circuit faults, follow current, and loss of power to part or all of the power system.

An open-circuit failure causes no effect on the power system other than an immediate loss of surge protection from that component. With proper overcurrent protection, an SPD that fails as a short circuit will act as an open-circuit failure. However, considerable line disturbances can be caused by the failure until the open circuit occurs and steady state is achieved.

A high-impedance short-circuit failure might draw a few amperes and therefore might persist unnoticed for some time. This can occur if an SPD's resistance drops enough to allow an abnormal leakage current to flow; however, the SPD does not go immediately into thermal runaway. This condition can produce a potential smoke or fire hazard if improper overcurrent or overheating protection methods are applied to the SPD.

A low-impedance short-circuit failure might resemble any other short circuit or fault on the power system. A voltage dip occurs while the overcurrent device operates. A voltage surge can occur following fault clearing. A loss of power occurs to loads downstream of the overcurrent protective device. Current-limiting fuses at the SPD component level can prevent loss of power to the protected system. In the absence of proper upstream overcurrent protection, the SPD must be capable of withstanding or interrupting the available symmetrical fault current, or a violent rupture can occur within the SPD.

6.7 Effects of SPD peripheral components on power systems

Power systems are sometimes used for purposes other than just delivering power. A power system may be used incidentally for transmitting signals or data within a facility. This transmission is done by adding a high-frequency signal on the mains. This use of high-frequency signals is possible only if there are no devices with significant shunt capacitance or series inductance connected to the mains. Some SPDs contain capacitors for attenuation of noise. The value of this added capacitance, which could be large, might not be stated in the specifications for the SPD, so that the possible interference of such a capacitor with signal transmission would not be recognized until it occurs.

Annex A

(informative)

Description of environment

A.1 The steady-state environment

Utility systems are designed to provide a stable supply of electric power. The steady-state voltage is typically maintained within specified limits. The steady-state service voltage limits for the USA, for instance, are described in ANSI C84.1-1989 and have a tolerance, under certain conditions, of $-5/+5.8\%$. This means that the steady-state voltage of the nominal 120 Vac system, for instance, could be as high as 127 V rms.

A.1.1 Power system impedance

Maximum power system impedance at the utilization level can be estimated on the basis that at 80% of rating, which is the maximum recommended by the National Electrical Code (NEC) (ANSI/NFPA 70-1993), the maximum voltage drop allowed by the NEC is 3% for a feeder and 3% for a branch circuit, but the total drop cannot exceed 5%, of the utilization voltage. For a 120 V line, for example, a 20 A circuit should therefore lose no more than 6 V at 16 A. This implies a source impedance at line frequency of $6\text{ V}/16\text{ A}$ or about $0.38\ \Omega$. For short branch circuits, the figure can be as low as 20% of this figure, or $0.07\ \Omega$.

The minimum line inductance likely to exist in any typical facility is $50\ \mu\text{H}$, while for long branch circuits the figure can reach several hundred μH . A reasonable upper limit of $200\ \mu\text{H}$ corresponds with an inductive impedance of $75\ \text{m}\Omega$ at 60 Hz, which corresponds fairly well with the $0.1\ \Omega$ calculated from a 2 V drop in a 120 V circuit at 16 A.

A.1.2 Available rms fault current

For within-building locations, close to a service entrance that happens to be supplied from a nearby transformer rated at 300 kVA or greater, rms fault currents even at the 120 V utilization level can range as high as 26 kA.

For more usual situations, typical within-building rms fault currents at the 120 V utilization level range from 200 A to over 1 kA. Fault currents at higher voltage utilization levels (with corresponding higher kVA ratings) are proportionately higher.

A.1.3 Available peak inrush current

Available peak inrush current is the peak value of the available rms fault current. However, since it is typically measured by simulating an electronic load drawing power from the mains, its actual measured value may be lower. While this is not a characteristic of the mains, it is a characteristic of measurements made on the mains, in context with the applications of mains power to electronic equipment.

Available peak inrush current is measured by monitoring the peak current that flows into a fully discharged, high-value electrolytic capacitor, which is connected to the power mains via a full-wave rectifier bridge, at the peak of the voltage wave. Thus, the measurement may include the effect of the impedance of the electronics, including the equivalent series resistance of the capacitor, which can range from $50\text{--}150\ \text{m}\Omega$. As a result, the measured value of the available peak inrush current may be lower than the peak of the available

rms fault current, by an amount typically ranging from 20–50% for long branch circuits, and by even greater amounts for short branch circuits.

A.2 Sources of power system disturbances

Many disturbances are generated at the user's facility by equipment; others result from an event on the utility system, such as lightning and equipment switching; others may be generated by other user-owned equipment on adjacent circuits (neighbor's circuits).

A.2.1 Lightning

Lightning-related surges in the low-voltage distribution system can be introduced in several different ways:

- a) Direct strokes to the low-voltage lines serving the building;
- b) Direct strokes to the high-voltage lines serving the step-down transformers and magnetically induced in the secondary winding;
- c) Direct strokes to the high-voltage lines and capacitively coupled to unshielded secondary windings of the power transformer;
- d) Surges that cause the arrester on the transformer primary to operate placing a surge on the ground and neutral wire that is common with the low-voltage secondary;
- e) Strokes to the earth near the transformer that create common-mode voltages in the secondaries;
- f) Strokes near the service entrance creating common-mode surges; and
- g) Strokes to the building housing the equipment creating common-mode surges in the chassis ground with respect to the power supply.

There are probably several other ways to introduce lightning-related surges that are combinations of the foregoing.

In addition to the surges (transients of less than 1/2 cycle) listed above, lightning is the cause of power frequency (60 Hz) overvoltages and undervoltages. When lightning causes a flashover on one phase of a three-phase line, the voltage at the flashover location and beyond (away from the source) is essentially zero, but toward the source the voltage increases as a function of the circuit impedance and the fault current. The 60 Hz voltage on the other two phases is highest at the flashover and beyond (the magnitude depending upon zero sequence impedance of the circuit) but approaches normal as one progresses toward the substation. These abnormal 60 Hz voltages exist until the flashover clears. Whether a sag or swell occurs at the affected location depends upon which of the three phases the service is connected to. The magnitude of the sag or swell is determined by the location of the flashover relative to the service transformer, and the duration of the sag or swell is a function of clearing time of the fault. Generally, flashovers require a breaker operation to clear the fault and deionize the air, which results in a total loss of voltage until the breaker recloses.

A.2.2 Faults (short circuits)

Faults on the utility system are classified as either temporary or permanent. The normal utility overcurrent protective practice is based on the assumption that most faults (on overhead systems) are temporary or can be selectively isolated in order to restore the remainder of the system.

A temporary fault may be due to a flashover from a lightning stroke, an animal contact, wind, etc. When a fault occurs, the line must be de-energized to stop the flow of fault current and to allow enough time to deionize the faulted path. To do this, a circuit breaker or line recloser opens to clear the fault, and then automatically recloses after some time delay. This reclosing can occur several times in an effort to re-establish continuity of service following a temporary fault.

The opening and reclosing times of circuit breakers are usually short enough that the operation of most lighting and motor-operated equipment will not be seriously affected. A computer or other sensitive load, however, may experience a total system shutdown unless preventive steps are taken, such as the application of an uninterruptible power supply (UPS), to maintain service to the load and allow for orderly shutdown. Temporary faults can be a serious problem for some industrial motor-operated equipment.

Permanent faults may be due to equipment failure, accidents with vehicles, a tree limb falling onto the line, etc. They result in service interruptions, which last from minutes to hours. Upon occurrence of a permanent fault condition, the breaker is usually programmed to operate three or four times in an attempt to re-establish power before it locks open. The fault must then be located and repaired before service is restored to all customers.

Most conductor-related faults on overhead distribution lines are of a temporary nature. By contrast, most faults on underground systems are permanent and take much longer to locate and repair.

A.2.3 Switching

Most switching operations, both utility and user, result in transient disturbances. These operations include fault clearing, load transfer, fault closing, etc. For example, rapid clearing and current-chopping produce voltage spikes generated by energy stored in inductive loads.

Although most users of sensitive equipment are aware that their equipment may be subjected to surges, many are not aware of the magnitude or source of the transients or the specific sensitivities of their equipment. Transients from within the customer's premises occur with load switching or fault clearing. The transient voltage results from the rapid rate of change of current through the inductance of the wiring. The magnitudes of these transients can be quite high.

Information from actual recorded data indicate that internally generated surges (impulses) caused by load switching are likely to be repetitive and can generally be associated with a specific device. Surges may be repeated several times a day.

A.2.4 Capacitor switching

In addition to voltage regulators and load tap-changers (LTCs), most utilities and many industrial commercial users employ shunt capacitor banks to help control the power factor or voltage profile by supplying reactive power to inductive loads, such as motors. Placed strategically on the circuit, shunt capacitors also reduce the losses associated with the primary circuit while improving the power factor.

To accommodate widely varying load conditions, most capacitor banks are switched automatically. When capacitor banks are energized, they produce transient voltages of about 2 times normal and lasting 1–8 ms. Certain sensitive loads may not be able to tolerate the normal switching transients associated with routine capacitor switching.

A.2.5 Motor starting

The starting of large motors is accompanied by a voltage sag resulting from the inrush current flowing through the system impedances. The maximum voltage sag occurs at the motor terminals and can have a noticeable or even objectionable effect on other customers in the area or on nearby loads sensitive to sags.

A.2.6 Partial discharge

Partial discharge occurs inside insulation. Partial discharge and corona can cause noise on the ac mains.

Annex B

(informative)

Bibliography

[B1] Bottrell, G. W., “Hazards and Benefits of Utility Reclosing,” in *Proceedings*, Power Quality '93, Oct. 24–29, 1993, pp. 260–275.

[B2] Hostfet, O. T., Hervland, T., Hansen, B., and Huse, J., “Coordination of Surge Protective Devices in Power Supply Systems Needs for Secondary Protection,” in *Proceedings*, 21, ICLP, Sept. 22–25, 1992.

[B3] IEEE Std 100-1992, The New IEEE Standard Dictionary of Electrical and Electronics Terms (ANSI).

[B4] Martzloff, François D. and Lai, Jih-Sheng, “Cascading Surge-Protective Devices: Options for Effective Implementation,” in *Proceedings*, PQA '92 Conference, Sept. 28–30, 1992.

[B5] Martzloff, François D. and Leedy, Thomas F., “Selecting Varistor Clamping Voltage: Lower is Not Better!” in *Proceedings*, 1989 Zurich International EMC Symposium, pp. 137–142.

[B6] Short, Thomas A., Burke, James J., and Mancao, Ramon T., “Application of MOVs in the Distribution Environment,” in *Proceedings*, 1993 IEEE PES Winter Meeting, 93 WM 047-1 PWRD.

[B7] Standler, Ronald B., “Calculation of Energy in Transient Overvoltages,” in *Symposium Record*, IEEE National Symposium on Electromagnetic Compatibility, May, 1989, pp. 217–222.

[B8] Standler, Ronald B., “Coordination of Surge Arresters and Suppressors for Use on Low-Voltage Mains,” in *Ninth International Zurich Symposium on EMC*, Mar., 1991, pp. 517–524.